

NOBLELIFT

**Manual & Semi-Electric Stacker
Adjustable Base Legs**

2200 LBS



SPN22

Lift Height >
Single mast: 63"
Duplex mast: 98"/118"



SFH22

< Lift Height
Single mast: 63"
Duplex mast: 98"/118"/137"

SFH22

Manual Hydraulic Stackers – Adjustable Base Legs

Model		SFH22-63	SFH22-98	SFH22-118
Capacity	lbs	2200	2200	2200
Lifting Height Max.	inch	63	98	118
Lifting Height Min.	inch	23/4	23/4	23/4
Fork Length	inch	36	36	36
Fork Width	inch	4	4	4
Outer width of forks	inch	8.5-33.5	8.5-33.5	8.5-33.5
Base legs I.D.	inch	36 to 48	36 to 48	36 to 48
Base legs O.D.	inch	43 to 54	43 to 54	43 to 54
Overall Length	inch	56	56	56
Overall Width	inch	43 to 54	43 to 54	43 to 54
Overall Height	inch	79 1/2	69 3/4	79 1/2
Load Center	inch	20	20	20
Front Caster Dia.	inch	4	4	4
Rear Caster Dia.	inch	7	7	7
Front Wheel Dia.	inch	5	5	5
Rear Wheel Dia.	inch	7	7	7
Wheel Type	inch	2 Rigid, 2 Swivel	2 Rigid, 2 Swivel	2 Rigid, 2 Swivel
Shipping Weight	lbs	705	795	850

SFH22

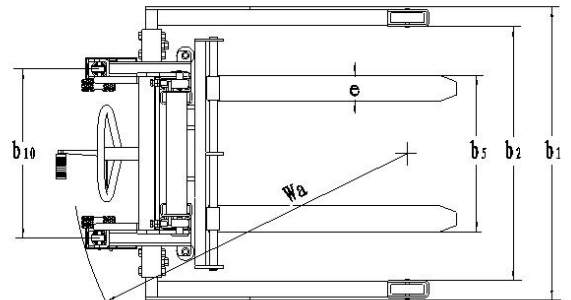
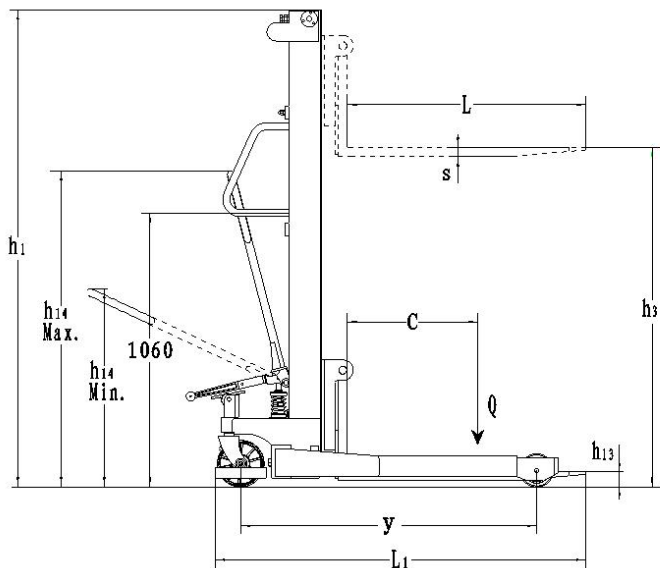

SPN22

Manual Hydraulic Stackers – Adjustable Base Legs

Model		SPN22-63	SPN22-98	SPN22-118	SPN22-138
Capacity	lbs	2200	2200	2200	2200
Lifting Height Max.	inch	63	98	118	138
Lifting Height Min.	inch	21/8	21/8	21/8	21/8
Fork Length	inch	42	42	42	42
Fork Width	inch	4	4	4	4
Base legs I.D.	inch	38 to 50	38 to 50	38 to 50	38 to 50
Base legs O.D.	inch	46 to 58	46 to 58	46 to 58	46 to 58
Overall Length	inch	661/2	661/2	661/2	661/2
Overall Width	inch	46 to 58	46 to 58	46 to 58	46 to 58
Overall Height	inch	80	72	82	891/2
Load Center	inch	24	24	24	24
Voltage	V	12	12	12	12
Rear Caster Dia.	inch	7	7	7	7
Front Wheel Dia.	inch	5	5	5	5
Rear Wheel Dia.	inch	7	7	7	7
Wheel Type	inch	2 Rigid, 2 Swivel	2 Rigid, 2 Swivel	2 Rigid, 2 Swivel	2 Rigid, 2 Swivel
Shipping Weight	lbs.	830	990	1050	1120

SPN22

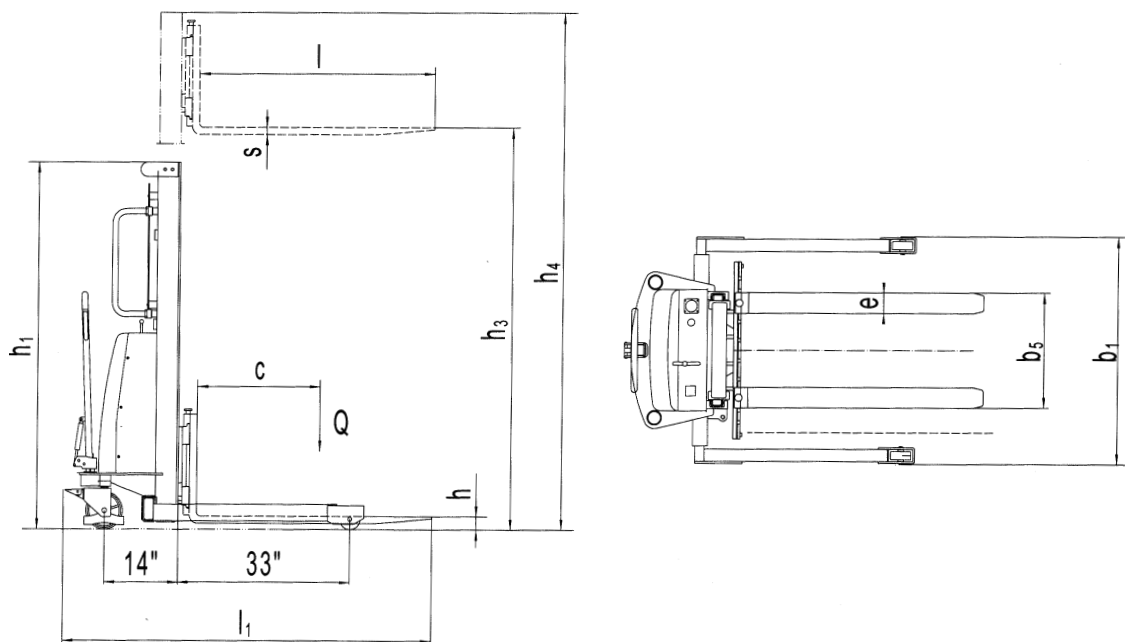

SPN22/SFH22

Manual & Semi-Electric Stacker

SFH22

Manual Hydraulic Stackers – Adjustable Base Legs

- For lifting loads, skids, racks, and objects. Forks adjust from side to side to accommodate skid widths.
- Feature fold-away hydraulic foot pump for raising loads.
- Two-swivel and two rigid casters provide four wheel support for heavy loads.
- Include wheel lock and safety screen to ensure safety during operation.

SPN22

Semi-electric Stacker - Adjustable Base Legs

- Forks adjust from side to side to accommodate skid widths.
- Adjustable forks lowers to the minimum height 2 1/8".
- Study and reliable mast made of rolled U-profiles. Hard chrome plated piston. Adjustable lifting chain. Powerful lift motor 2.1 HP.
- Integrated 150 AH maintenance free battery supplies strong power to effect frequent lifting tasks, an integrated charger facilitates easy and reliable charging of the integrated battery.



SJF MATERIAL HANDLING

211 Baker Avenue W, Winsted, MN 55395

(320) 485-4974 | (800) 598-5532

onlinesales@sjf.com | shop.sjf.com