

LITHIUM-ION

OP8.5

850 lbs. Capacity

Lithium-Iron Order Picker



Capacity
850lb



Lithium-ion
Battery

Robust
Design

CAN-bus
CAN-bus

Highly
Cost Effective

Easy
Maintenance

Low noise

Why choose between price and quality **WHEN YOU CAN HAVE BOTH!**



HIGHLIGHTS

- ▶ American Curtis Travel Controller with CAN-bus control
- ▶ High performance AC drive motor and DC lifting motor
- ▶ Lithium battery: 24V/60Ah with Built-in 24V/25Ah charger
- ▶ Loading capacity 850lbs
 - 220lbs load tray
 - 330lbs load deck
 - 300lbs operator compartment
- ▶ EPS-Electric Power Steering system
- ▶ Smart handle with Keyless Pin-Code Panel and RFID Card
- ▶ Electric Lifting and Lowering Buttons
- ▶ High-performance handle with dual-hands sensing operation
- ▶ LCD display: speed, usage time, power, steering, fault code, alarm and more
- ▶ Emergency lowering switch

OP8.5

850 lbs. Capacity

Lithium-Iron Order Picker

The OP8.5 Lithium-iron Order Picker is compact, highly efficient and designed for many applications, including narrow aisle. It offers an impressive 850lbs load capacity, zero-turning radius, the ability to pick from both sides of the aisle and is capable of multiple shift operation. Engineered with a low profile, it can easily enter elevators and pass under doorways. Increase your work productivity with this quiet, very low maintenance, ultra-smooth, lithium-iron order picker.

HIGH PERFORMANCE AND HIGH EFFICIENCY



360° Zero-turning radius of 51.2 inches



Can also be used for overhead work and facility maintenance.

The OP8.5 is equipped with a Curtis controller, allowing it to lift, travel and steer simultaneously, while maintaining smooth and safe operation. Dual drive AC motors paired with electric power steering provide superior maneuverability, high performance and low operating/maintenance costs.

GREAT VISIBILITY

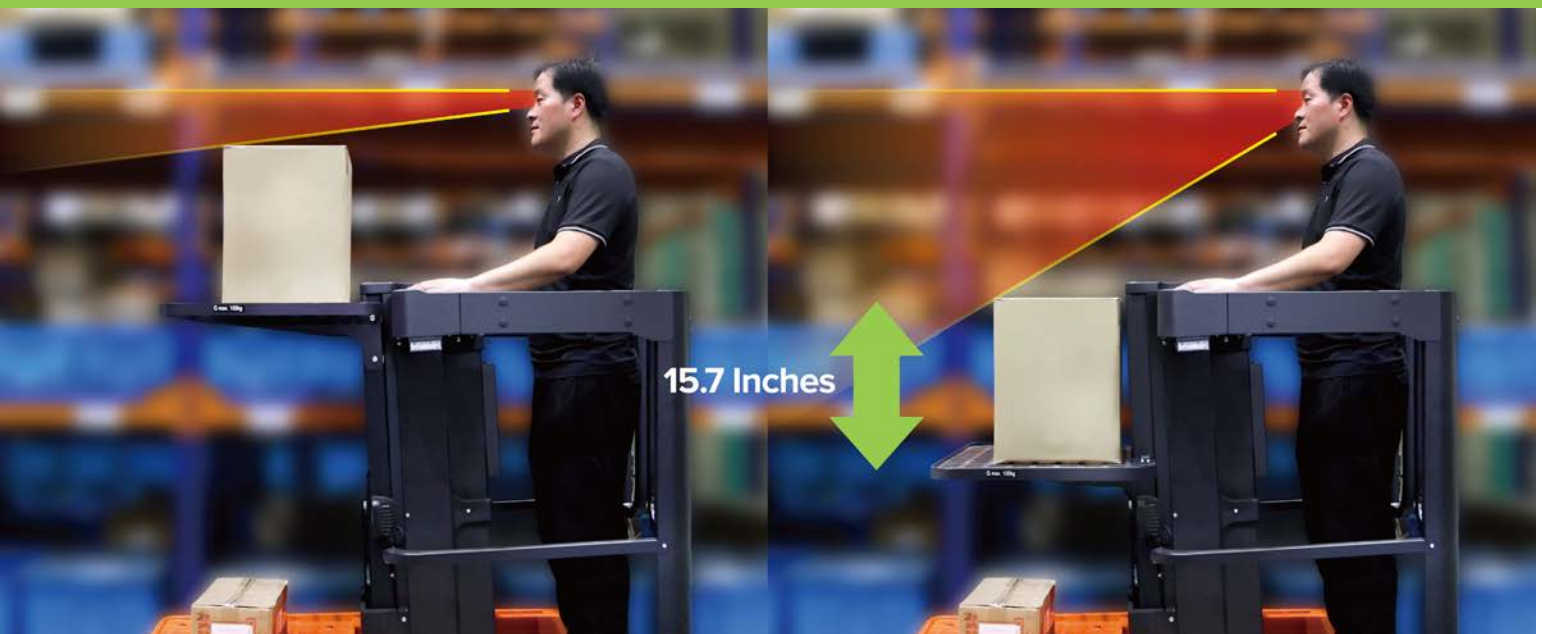

Adjustable front shelf can be raised and lowered to ensure operator's field of view is not obstructed.

INTELLIGENT. SAFE. RELIABLE.



The OP8.5 will not operate until the automatic doors have fully closed.

High-strength aluminum alloy profiles provide stability and low center of gravity.



LCD display shows safety warnings, speed, steering angle and fault codes for easy operation and troubleshooting.



Keyless PIN code lock or RFID card access simplifies access when several users operate one truck.



Left and right multi-function handles can be customized and provide simultaneous lifting, traveling and steering. Handles are equipped with operator presence buttons to ensure safe operation.



Side lights and headlight provide excellent visibility to operator even in poor lighting conditions. Vehicle is also equipped with a buzzer, warning light, rear light and safety blue light.

CAN-bus



CURTIS

Easily check order picker's condition and troubleshoot with Curtis controller and CAN-bus technology.

SPEED AND DECELERATION

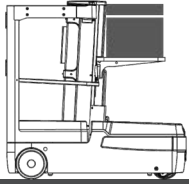

Travel speed 3.8mph

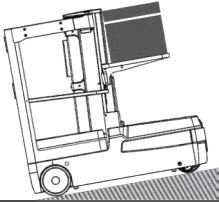

Gradeability, laden 5%

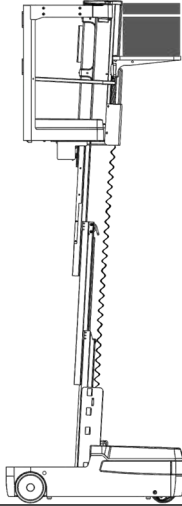

Lifting speed, laden .65ft/s

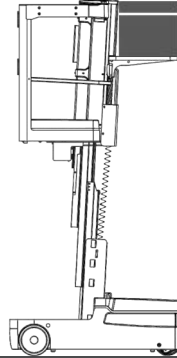

Lowering speed, laden .68ft/s

Proportional hydraulics provide smooth lifting. The working height can reach 16.4 feet, allowing operator to collect materials from the 3rd level of rack. Driving speed reduces with the increase of height, ensuring safe and stable operation.



Travel speed .8mph
Lifting height between 59-118 inches



Travel speed 3.8mph
Lifting height below 19.6 inches



Travel speed 2mph
Lifting height between 19.6-59 inches

LONG LASTING AND SAFE LITHIUM-ION POWER

NOBLELIFT uses Lithium-Iron Phosphate batteries, the longest lasting and safest lithium-ion battery available. Our lithium-iron batteries are equipped with a Battery Management System (BMS), thermal management system, and an automotive-grade DC high-voltage control system. BMS manages charging and discharging data to ensure safety throughout its life cycle.



OP8.5 Lithium-Iron order pickers have a 3 year or 6,000 hours warranty on the lithium-Iron battery.

ADVANTAGES OF LITHIUM-ION POWER

Fast-charging maintenance-free Lithium-Iron battery is fully charged in 1-2 hours. Battery can be opportunity charged during user breaks and during shift changes which allows the truck to run continuously through multi-shift operations. No battery changes are necessary.



24V/60Ah Lithium-iron battery has connection terminals with screws and is protected inside the steel case.

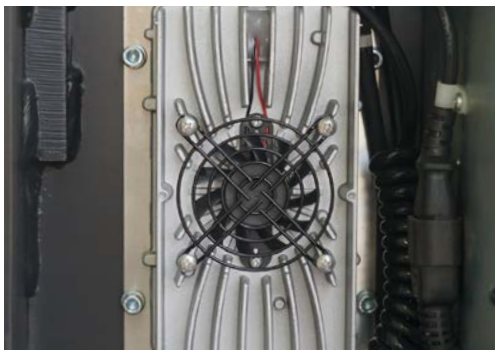

Built-in 24V/25Ah charger provides added convenience.

LITHIUM BATTERY ADVANTAGES

Lead-Acid Battery		Lithium Battery
Lower fleet availability - Work is interrupted because battery needs to be fully charged before next use	Productivity - Memory Effect 	100% Fleet availability - Opportunity charging allows battery to be charged in between use
Periodic battery replacement	Service Life 	Batteries last 3 times longer and do not need to be replaced
Outsourced or in-house maintenance personnel required	Ongoing Maintenance 	No maintenance cost
8-10 Hours - 2 or more batteries per lift truck	Charge Duration 	1-2 Hours - 1 Battery per lift truck
Build an expensive battery room with ventilation	Battery Room 	No battery room needed
Releases hydrogen while charging - Can result in explosion - Acid burns can happen during maintenance	Dangerous Substances 	No dangerous substances
Power loss	Power Savings 	No power loss - Reduces energy consumption by 35%

Identification				
1	Manufacturer			NOBLELIFT
2	Model			OP8.5
3	Drive (electric – battery or mains, diesel, petrol, gas, manual)			Electric
4	Vehicle capacities	Operator compartment	lb	300
		Load tray shelf	lb	220
		Load deck	lb	330
5	Vehicle weight (with battery)	lb		1,521
6	Platform step height	in		12.5
Dimensions				
7	Platform lift height	in		118
8	Platform fully lowered	in		54.9
	Platform fully raised	in		161
9	Overall extended height	in		163.3
10	Work height	in		196.8
11	Overall collapsed height	in		57.2
12	Vehicle length	in		57.5
13	Vehicle width	in		29.5
14	Wheels, number front / rear (x=driven wheels)	in		1 x+2/2
15	Rear drive wheels (d x w)	in		256 x 80
	Front caster wheels (d x w)	in		220 x 70
Performance				
16	Minimum turning radius	in		51.2
17	Service brakes	h ₁		Regenerative
18	Parking brake	h ₂		Electric released
19	Grade clearance, laden / unladen	%		5/8
20	Travel speed, laden / unladen	mph	0-19.6in 3.8 / 3.8	19.6-59in 2 / 2 59-118in .8 / .8
21	Lift speed, laden / unladen	ft/s		.65 / .72
22	Lowering speed, laden / unladen	ft/s		.68 / .59
Batteries				
23	Lead acid batteries (5h) (optional)	V/Ah		24/106
	Energy consumption acc. to VDI cycle	kWh/h		2x35
24	Li Batteries (standard)	V/Ah		24/60
				17
25	Charger - built-in (for lead acid option)	Amp		12
	Charger (Li) - built-in (standard)	Amp		25
Motor				
26	Drive motor, output S2 60 min.	W		650
27	Lift motor (operator compartment)	W		2,200
28	Lift motor (load tray)	W		800
Others				
29	Type of drive control			AC speed control
30	Sound pressure level at the driver's seat	dB(A)		69

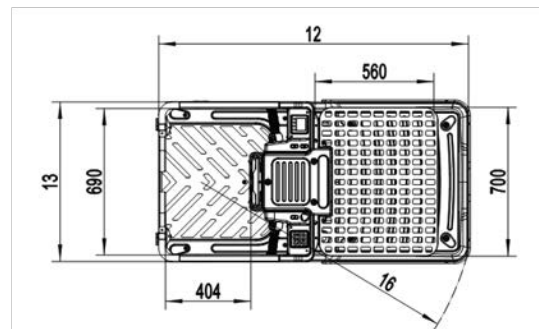
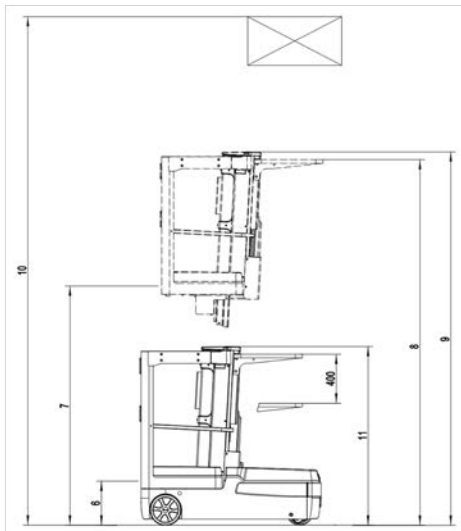

A GLOBAL LEADER

NOBLELIFT is a global leader in Lithium-ion Technology. We manufacture more than 200 categories and around 30 series of each product. Our products are designed to meet different application demands and are well accepted by our customers in more than 100 countries and regions in Europe, America, Asia, Africa and more.

Products include: sit-down forklifts, narrow aisle forklifts, walkie-stackers, order pickers, electric pallet trucks, scissor lifts, tuggers, scrubbers, lift tables, manual pallet jacks and more.



FORKLIFTS



NARROW AISLE



STACKERS



POWERED PALLET TRUCKS



SCISSOR LIFTS



TUGGERS



SCRUBBERS

AUTHORIZED DEALER



SJF MATERIAL HANDLING

211 Baker Avenue W, Winsted, MN 55395
(320) 485-4974 | (800) 598-5532

onsales@sjf.com | shop.sjf.com | sjf.com