

Loading Dock Bumper

Installation Instructions



Important notes

- Create a highly visible barrier around the area you will be working. The Portable Safety Zone or RapidRoll Portable Barrier System, both by Ideal Warehouse Innovations, are excellent tools for this.
- Loading dock bumpers are installed directly onto the dock wall or welded to bumper mounting brackets before being installed onto the dock wall.
- Use appropriate Personal Protective Equipment such as gloves, safety glasses, hearing protection and protective shoes.

Tools required for installation

- Measuring tape
- 2' level
- Hammer drill with a 3/4" drill bit
- Welding equipment (depending on installation method)

Methods of Installation

The most common method for installing bumpers and brackets is using wedge anchors. The alternative method, if sufficient embedded steel is available, is to weld the bumpers/brackets or to use a combination of both methods (e.g. weld one side, anchor the other). For added convenience during installation, having bumpers factory-welded to the bracket can save valuable installation time.

This installation guide covers installation of the most common styles of bumpers (E.g., Laminated, Steel-Faced, etc.) which have steel angles or flat plates on each side. If other styles of bumpers are being installed (E.g., Molded Rubber) the anchor requirements can be different however the principles behind the location remain the same.

Anchors

- For concrete installation, use 3/4" diameter x 4-1/2" wedge anchors (min. suggested length, could be different if suitable). Available from Ideal Warehouse Innovations (Item #28-8010).
- Minimum hole depth is 4"
- Minimum effective embedment depth is 3.25"
- Installation torque is 110 lbs
- Minimum edge distance is 4.5"

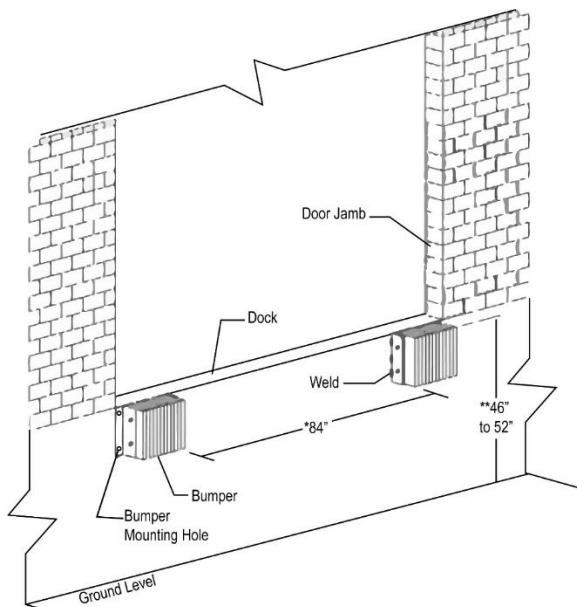

Dwg. 1: Bumper Location Concept View (P1 Style Bumpers Shown)

** 84" is the most common inside dimension for centered mounting of dock bumpers where no dock leveler exists. If a dock leveler exists, it is common to weld the inside edge of the dock bumper to the curb angle of the dock leveler pit, if the curb angle exists and is in good enough condition to support this type of anchoring. The best mounting style in this case is a "P1" style bumper.*

*** If the actual dock height is less than 46", an above dock riser bracket may be required to provide proper dock protection.*



Standard



P1 Style



P2 Style

Anchoring Fastening Method:

1. Identify the exact bumper position on the loading dock referencing *DWG.1 – Bumper Location Concept View*.
2. Mark location of mounting holes on the wall. Make sure that any hole is distanced a minimum of 4.5" away from the concrete or brick wall edge.

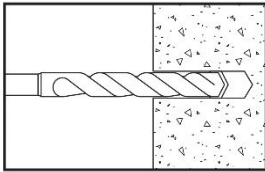

3. Using a drill bit whose diameter equals the anchor diameter, drill holes with depths of at least ½" more than your embedment depth. The tolerances of the drill bit used must meet the requirements of ANSI Standard B212.15.

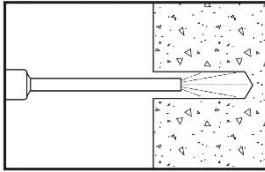

4. Blow the hole clean of dust and other material. Do not expand the anchor prior to installation.

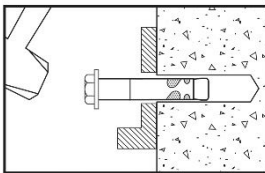

5. Position the washer on the anchor and thread on the nut. Drive anchor through the bumper/bracket into the anchor hole until the nut and washer are firmly seated against them, and the bumper sits flat on the wall surface. Be sure the anchor is driven to the required embedment depth.

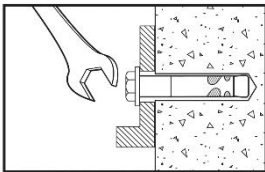

6. Tighten the anchor by turning the head 3 to 5 turns past finger tight.

Bumper Welding Fastening Method:

1. Identify the exact bumper position on the loading dock referencing *DWG.1 – Bumper Location Concept View*.

Note: Welding bumper to the dock door jamb and some types of dock leveler curb angles is not recommended. Some older designs do not have enough structural integrity to support against shocks transmitted from trailer impact. However, many later dock leveler models are formed using sound structural methods and may be able to support this type of installation. Verify with dock leveler contractor for accurate information.

2. Position bumper at its location; make sure that bumper sits flat on the wall surface and installed location of bumper will not interfere with leveler operations. Tack weld bumper to the dock steel structure first. Finish welding by applying 0.25" wide and 2" long weld at 3 places on each welded side (see DWG. 3)

Note: We recommend painting your welds for added protection against rusting.

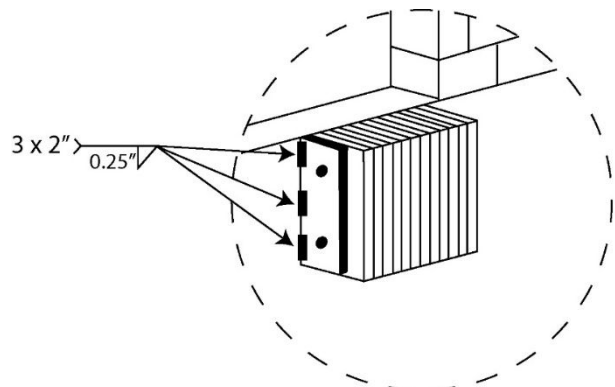

DWG. 3: Bumper Welding Fastening Method
(P1 Style Bumper shown)