

**AUTO
STAND
PLUS**



**IDEAL WAREHOUSE
INNOVATIONS INC**
Protecting Your People

AutoStand Plus Trailer Stand Operation Manual

Product intended to prevent trailer up-ending and landing gear collapse by shouldering the weight in heavy-duty loading dock environments.

Original Instructions

Important notes:

- Only trained and authorized individuals should use this product.
- When the AutoStand Plus is first received, the tires must be attached. Slide each tire over each axle, place washer on, insert cotter pin and use pliers to bend the ends of the cotter pin to prevent it from falling out.
- Use only original Ideal Warehouse Innovations parts to service this product.
- Do not maneuver on steep surfaces; use only on stable, flat surfaces.
- Make sure wheels are *not* in contact with ground during loading process.
- Use caution in heavy rain, snow or wet environments.

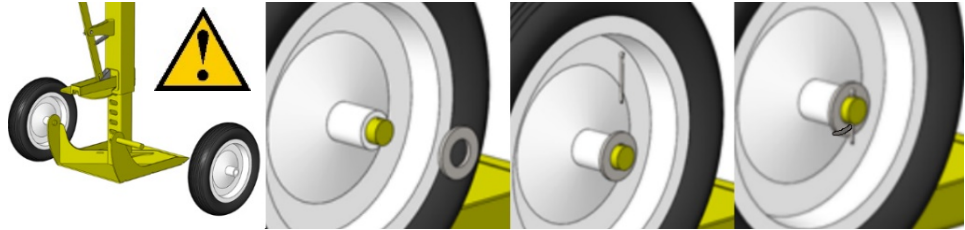

Before you begin:

- Complete a visual inspection of the AutoStand Plus for any obvious maintenance issues.
- Be careful moving around the loading dock area to ensure it is safe to move around the area.
- Use appropriate personal protective equipment such as gloves, safety glasses, safety vest, hearing protection and protective shoes.



Step 1:

Position AutoStand Plus under nose of trailer centered from both sides, ensuring the stand is positioned approximately in the center of the trailer, 3 inches (8cm) to 6 inches (16 cm) deep, under the nose.

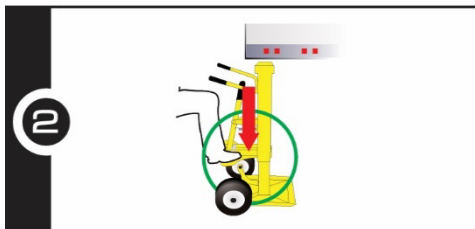

Step 2:

Step on the foot plate and press down firmly. You will release pressure on the locking pin mechanism. This will allow you to release the spring-biased locking mechanism.

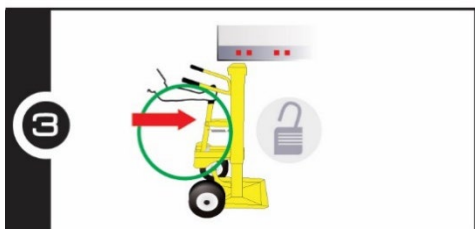

Step 3:

To release the spring biased locking mechanism; push forward on the hand lever while pressing down on the foot plate. This will allow the AutoStand Plus to rise to the underside of the trailer.

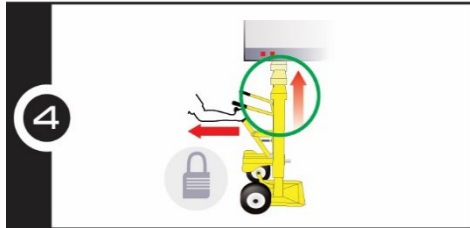

Step 4:

Once the AutoStand Plus has reached the underside of the trailer, pull back on the hand lever, locking the unit into place. Note: You may need to step on the foot plate to find the closest hole for locking pin.

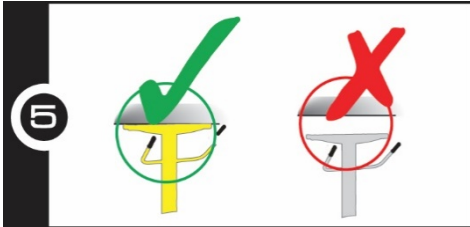

Step 5:

Ensure the AutoStand Plus is as close to the underside of the trailer as possible. In some cases there will be a small gap between the top of the stand and the underside of the trailer.



Step 6: Ensure the AutoStand Plus is in the correct locked position to avoid potential injury to personnel or damage to equipment. The locking pin should be fully inserted through the center mast of the stand. If the pin is not fully inserted, repeat steps 3-5.



Critical safety tip:

If the AutoStand Plus Trailer Stand does not have enough range to reach the underside of the trailer, use other means to protect against landing gear collapse and trailer tip over.

Removing the AutoStand Plus Trailer Stand

Complete all of the previous steps in reverse order.



Critical safety tip:

If you are unable to remove the locking pin, there may be an unsafe condition the AutoStand Plus has prevented. **Removing it at this point may cause a larger accident.** Contact the loading dock supervisor for assistance as the trailer may need to be supported by other means before the AutoStand Plus can be safely removed.

Once removed, store the unit out of the way of dock traffic, indoors, and complete a visual inspection to ensure there are no obvious maintenance issues.

Warranty Statement

Ideal Warehouse Innovations, Inc. warrants for a period of three hundred and sixty-five (365) days from date of installation, or three hundred and seventy-five (375) days from date of shipment, whichever shall occur first, that all products and service parts shall be free from defects in workmanship and material. If the equipment or any part thereof, is returned, transportation charges pre-paid, within the periods specified above, and if examination by Ideal Warehouse Innovations, Inc. discloses to its satisfaction that the said equipment or part thereof has been defective in workmanship or material, it will deliver to the purchaser, without charge, parts of the first class workmanship and material in exchange for any parts so found to be defective, and Ideal Warehouse Innovations, Inc. is limited to said exchange.

This warranty shall not apply: (1) to maintenance service or adjustment; and (2) to any equipment which shall have been repaired or altered outside of Ideal Warehouse Innovations, Inc. or its authorized service representatives.

These warranties are in lieu of all other warranties, expressed or implied, including, without limitation, warranties of merchantability and fitness for purpose, all other representations to the first user purchaser, and all other obligations or liabilities, including liability or incidental and consequential damages, on the part of Ideal Warehouse Innovations, Inc. No person is authorized to give any other warranties or to assume any other liability on behalf of Ideal Warehouse Innovations, Inc. unless made or assumed in writing by Ideal Warehouse Innovations, Inc.

Recommended Safety Inspection and Maintenance Schedule

Inspect for	Action	Key
Before each use:		
A visual check should be performed before each use.	Look for any bent parts (i.e. handles, top cover, axles), check for any broken welds, and make sure locking pin is present.	
Monthly:		
Locking pin insertion through mast. Pin must travel freely in and out of the mast using the lever mechanism and be spring-biased INTO the mast.	1. Clean pin and channel that it slides in.	1
	2. Spray pin with silicone spray. Do not use heavy oils or grease that will trap dirt.	2
	3. Check that spring is fastened properly and is in working order.	3
	4. Check that lever handle is fastened properly and is in working order.	3
	5. Replace or repair parts if necessary.	
Up and down function of stand. Should raise automatically when locking pin is pulled out and lower by pushing on foot pedal.	1. Raise unit to top of travel, clean and re-grease bottom section of mast.	4
	2. Check internal gas shock.	5
	3. Replace or repair parts if necessary.	
Bent or damaged top channel	Replace or repair if necessary.	
Bent, damaged or missing handlebars, critical fasteners, tires, etc.	Replace or repair if necessary.	
Every 90 days:		
Inspect for bent, damaged or missing handlebars, fasteners, grips, tires, labels, etc.	1. Check to ensure all moving parts operate smoothly. 2. Clean labels so instructions are clear and visible. 3. Replace or repair if necessary.	

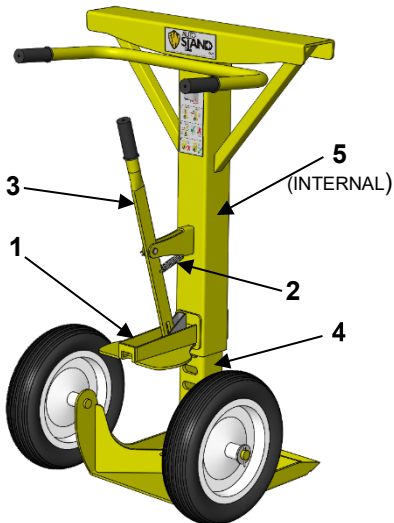

Gas Shock Removal/Installation Instructions

⚠ DANGER !!!

This is the highest level statement. Failure to follow the listed instructions will most likely result in severe injury or death.

⚠ CAUTION !!!

The statements used with this level of warning deal with a safe operating procedure. If the procedure is ignored, the possibility of personal injury may exist.

⚠ WARNING!!!

This is a statement of serious hazard. Failure to follow the listed instructions could place the individual at risk of serious injury or death.

IMPORTANT!!!

IMPORTANT is used to draw attention to a procedure that needs to be followed to prevent machine or property damage.

Step 1:

Post safety warning and barricade work area, to prevent unauthorized use of the area while service work is being performed.

Step 2:

Ensure the Stand is in a vertical upright position. Remove and store the locking pin. Allow the Stand to rise to its maximum raised position (as high as the unit will go).



Step 3:

Locate the top channel nut and bolt assembly for the gas shock (located under the top channel assembly). Using a 14mm (or 9/16") deep socket and ratchet on the bolt head and a 14mm (or 9/16") deep socket on the nut, loosen the assembly completely. Remove nut and bolt (save for re-use).

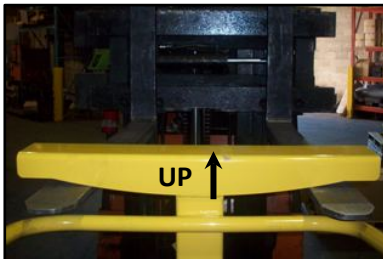

Step 4:

Using a forklift (recommended) or 2 people (one on each side), lift the top channel assembly off the lower tube assembly. Place the top channel assembly in a safe location for re-use later.



Step 5:

Locate the lower nut and bolt assembly for the gas shock, (located at center of the lower tube assembly). Using a 14mm (or 9/16") deep socket and ratchet on the bolt head and a 14mm (or 9/16") deep socket on the nut, loosen the assembly completely. Remove nut and bolt assembly (save for re-use).

Note: Do not over tighten.



Step 6:
Remove gas shock.

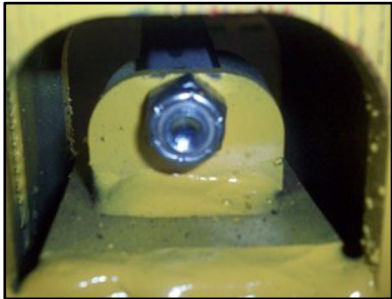

Step 7:
You are now ready to replace the gas shock.
Using the same nut and bolt removed in steps 3 & 5 from the original gas shock, place gas shock eyelet between the gas shock holder on the lower tube assembly. The silver part of the gas shock should be facing down. Using your fingers thread the bolt through the gas shock holder and gas shock eyelet and place nut on opposite side. Using a 14mm (or 9/16") deep socket and ratchet on the bolt head and a 14mm (or 9/16") deep socket and ratchet on the nut, tighten the assembly together.

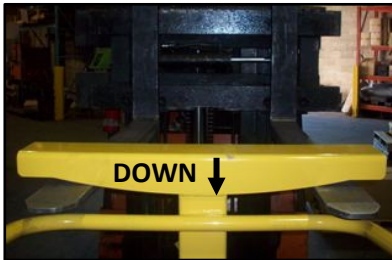

Step 8:
Using a forklift (recommended) or 2 people (one on each side), lift the top channel assembly over the lower tube assembly and lower slowly. Ensure that you line-up the gas shock holder with the eyelet on the gas shock.



Step 9:
Using your fingers thread the bolt through the gas shock holder and gas shock eyelet and place nut on opposite side.

Step 10:
Using a 14mm (or 9/16") deep socket and ratchet on the bolt head and a 14mm (or 9/16") deep socket and ratchet on the nut, tighten the assembly together.

Note: Do not over tighten.

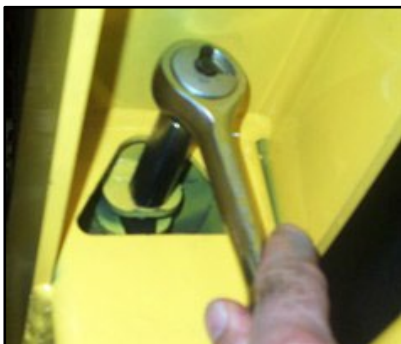

Step 11:
Replace Locking Pin. Test unit by stepping on foot plate ensuring the unit travels up and down (lowers and rises) freely.

Congratulations! You have successfully completed your installation.

AutoStand Plus Trailer Stand Parts Listing

Key	Part #	Description	Quantity Per Stand
	60-5444	Complete AutoStand Plus Trailer Stand	1
1*	50-9263	ASP TopTube&Chan.Asy.w/Lever,Hand. Bar&Foot Ped. (1st generation)	1
1*	50-9263-1	ASP TopTube&Chan.Asy.w/Lever,Hand. Bar&Foot Ped. (2nd generation)	1
2	50-9269	Handle Bars, with grips (must weld on site)	1
3	50-8546	1-1/4" Dia. Handle Bar Grips (two on each handle bar, one on lever)	3
4	50-9273	Auto-Stand Plus Top Channel label	1
5	50-9271	Auto-Stand Plus instruction label	1
6	50-8601	Gas Shock w/ Nut & Bolt (internal) XP6679 (Internal)	1
7*	50-9261	Front Angled Base Plate & Lower Tube Assembly (1st generation)	1
7*	50-9261_1	Front Angled Base Plate & Lower Tube Assembly (2nd generation)	1
8*	50-9268	1" Axle Bolt (8-3/4" L) with (2) Nuts (1st generation)	2
8*	50-8533-6	Axle Cotter Pin 3/16 x 2" with 1.750" OD Washer (2nd generation)	2
9	50-9267	Lever Mechanism Retraction Spring	1
10	50-9266	Clevis Pin (For Lever Mech. top and bottom)	2
11	50-9265	Lever Mechanism (Includes Locking Pin)	1
12	50-8532	16" Trailer Stand Tire White	2

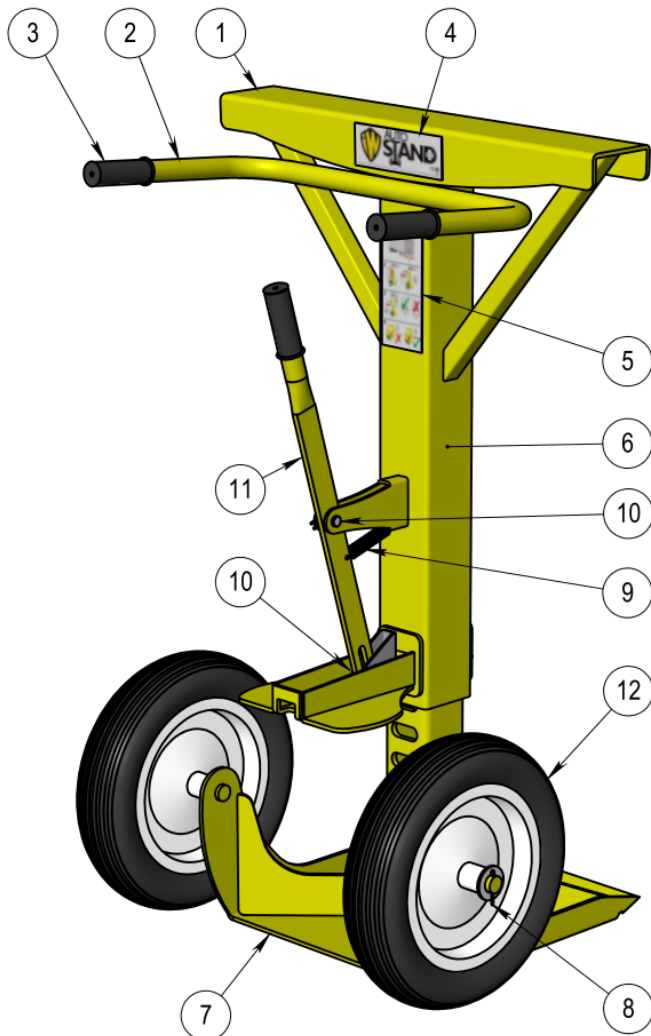

***CHECK SERIAL NUMBER**

If the serial number on the Top Channel Label (Key 4) is ASP2102001 or higher, use 2nd generation parts.

If the number is lower or does not exist, use 1st generation parts*.